

SHORT SECTION

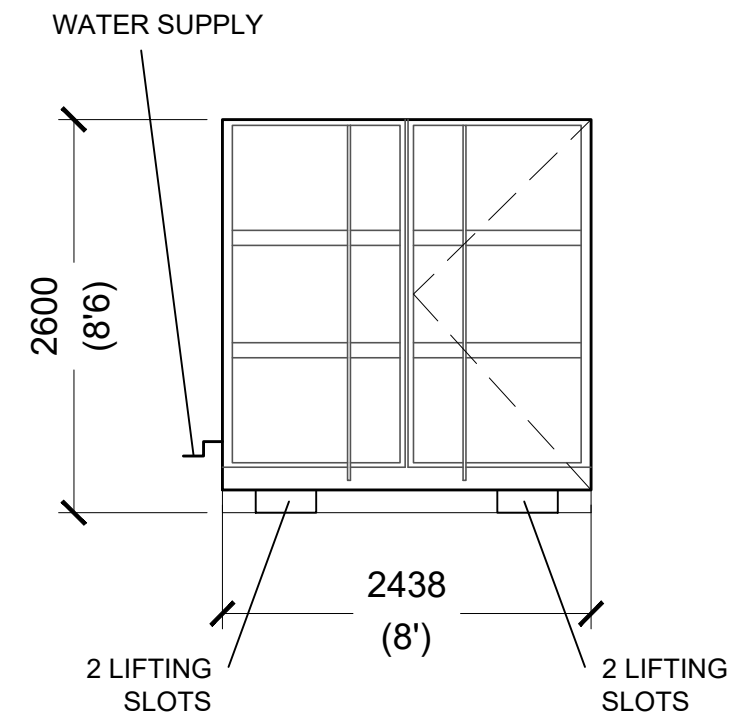

FRONT ELEVATION

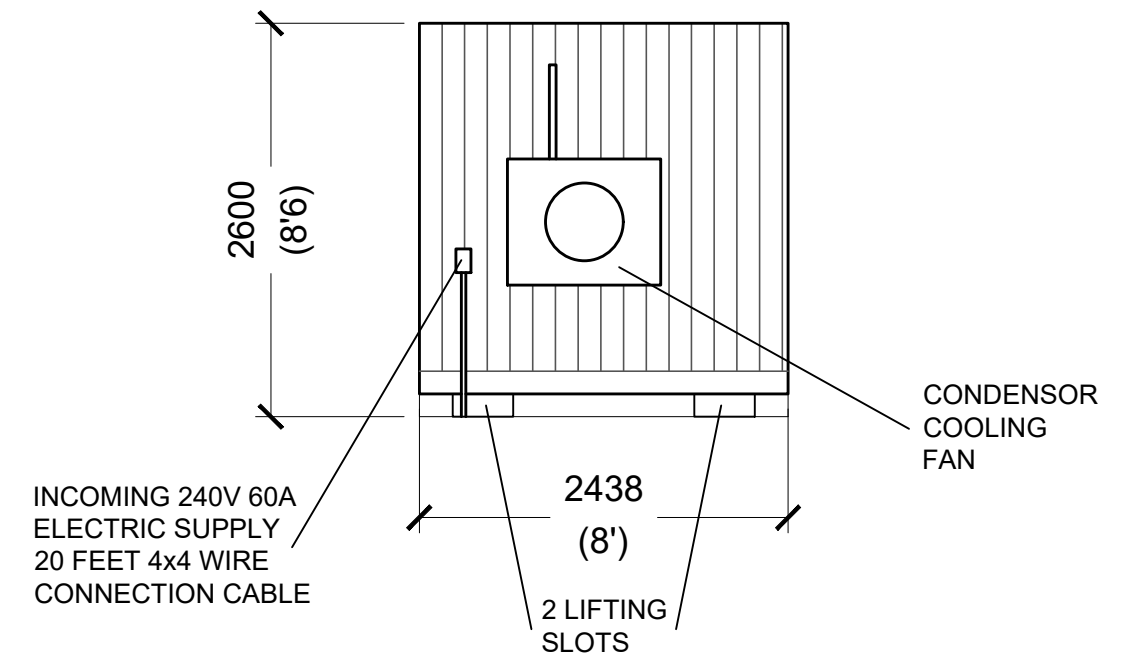

REAR ELEVATION

**Overall Dimensions:**

- Cubic Volume: 33.2 cubic m
- Door Width: 2340 mm
- Door Height: 2280 mm ( only ONE DOOR OPEN ON THE RIGHT HAND SIDE WHEN FACING )
- Tare Weight: 2200 kg

**Exterior dimensions**

- 20' long
- 8' wide 2438m
- 8.6' tall
- Exterior super-paint by Sherwin Williams.

**Fittings (temp control and electrical)**

- HVAC – 3 ton LG mini split system with remote control.
- 240 volt electrical system – 60 amp with exterior system disconnect and 20 feet of #4X 4 wire connection cable.
- 220v outlets connected to time clock plus general purpose 110v outlets for fans and other use. – Number of outlets can vary but assume 5
- 2 Tank CO2 system

**Lighting**

- Super strut overhead system to support lights, cables, etc.
- Maximum 5 x 1000 watts high pressure sodium, manufactured by Gavita, with double ended bulbs. And 2 x T5 lights for vegetation area.

**Walls and Ceiling:**

- 2" Polyiso core insulated walls with aluminum outer barrier
- .18" x 24" utility sink with cold water only tap. and garden hose connections on interior and exterior in line connector.

**Flooring:**

- 1/2" Dow blue foam flooring insulation.
- EPDM rubber membrane ( black). 100% Waterproof flooring throughout



Contact Information  
 Email: info@growpodco.com  
 Hours  
 Mon-Fri: 9:00AM-5:00PM  
 Sat & Sun: Closed  
 Address: 42 Garden Lane  
 Pine Island, NY 10969

# 40 foot Standard Container - Specifications

